

12Gbps Video SFP Optical Transceiver, 20km Reach 3CV-SFP+12G-LR

Features

- ü SD/HD/3G/6G/12G-SDI SFP Transceiver
- ü ST 259, ST 292-1, ST 424, ST-2081 and ST-2082 compatible
- ü Metal enclosure for Lower EMI
- ü 1310nm DFB laser transmitter
- ü Supports SDI pathological patterns for SD-SDI, HD-SDI, 3G-SDI, 6G-SDI
- ü Compliant with SFP MSA
- ü Duplex LC connector
- ü The module's receiver contains reclocker
- ü ROHS compliant(lead free)
- ü single 3.3V power supply
- ü Hot-pluggable SFP footprint
- ü Operating case temperature range: 0 to +70° C



Applications

- ü ST 259, ST 292-1, ST 424, ST-2081 and ST-2082 Electrical-to-Optical Interfaces
- ü UHDTV/HDTV/SDTV Service Interfaces

Description

3C-LINK's Video transceiver is designed to transmit/receive data rates from 50Mbps to 11.88Gbps , compliant with SMPTE ST 2082-1 (12G UHD-SDI), ST 2081-1 (6G UHD-SDI), ST424 (3G SDI), ST 292-1 (HD-SDI), and ST 259 (SD-SDI). 3C-LINK's Video transceiver supports SDI pathological patterns signals.

The transceiver includes these sections: a DFB laser, a PIN photodiode integrated with a trans-impedance preamplifier (TIA) , Reclocker ,and a MCU controller. The transceiver is compliant with SFP Multi-Source Agreement (MSA) .

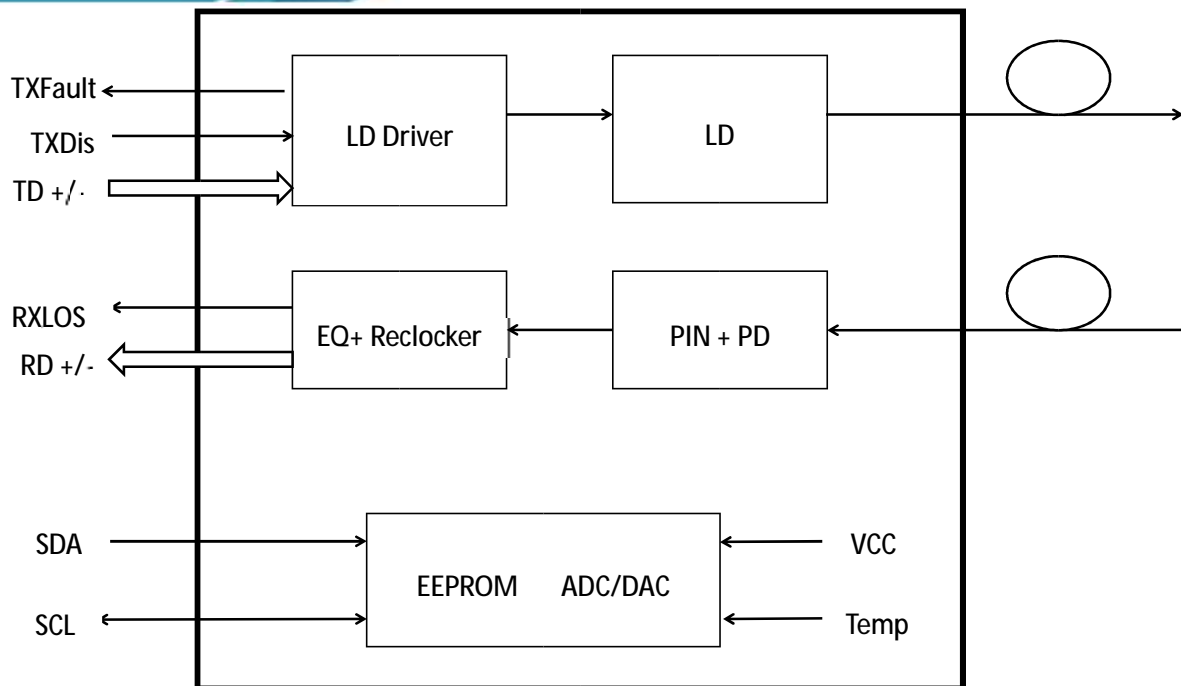

Figure 1. Module Block Diagram

Absolute Maximum Ratings

Parameter	Symbol	Min	Max	Unit
Supply Voltage	V _{cc}	-0.5	4	V
Storage Temperature	T _s	-40	+85	°C
Operating Humidity	-	5	85	%

Recommended Operating Conditions

Parameter	Symbol	Min	Typical	Max	Unit
Operating Case Temperature	T _c	0		+70	°C
Power Supply Voltage	V _{cc}	3.13	3.3	3.47	V
Power Supply Current	I _{cc}		300	450	mA
Data Rate			12		Gbps

Optical and Electrical Characteristics

Parameter	Symbol	Min	Typical	Max	Unit	Notes
Transmitter						
Center Wavelength	λ _c	1300	1310	1320	nm	
Spectral Width (-20dB)	σ			1	nm	
Side Mode Suppression Ratio	SMSR	30			dB	
Average Output Power	P _{out}	-3		1	dBm	1

Extinction Ratio		ER	3.5			dB		
Data Input Swing Differential		V _{IN}	400		1000	mV	2	
Input Differential Impedance		Z _{IN}	90	100	110	Ω		
Rise/Fall Time (20%~80%)		SD-SDI			1500	ps	3	
		HD-SDI			270			
		3G-SDI			135			
		6G-SDI			80			
		12G-SDI			45			
Output Jitter	Timing Jitter	SD-SDI			0.2	UI	4	
		HD-SDI			1			
		3G-SDI			2			
		6G-SDI			4			
		12G-SDI			8			
	Alignment Jitter	SD-SDI						0.2
		HD-SDI						0.2
		3G-SDI						0.3
		6G-SDI						0.3
		12G-SDI						0.3
TX Disable	Disable		2.0		V _{cc}	V		
	Enable		0		0.8	V		
TX Fault	Fault		2.0		V _{cc}	V		
	Normal		0		0.8	V		
Receiver								
Center Wavelength		λ _c	1260		1580	nm		
Receiver Sensitivity@ 11.88Gbps					-11	dBm	5	
Receiver Sensitivity@ 5.94Gbps					-13	dBm		
Receiver Sensitivity@ 2.97Gbps					-15	dBm		
Receiver Overload			1			dBm	6	
LOS De-Assert		LOS _D			-18	dBm		

LOS Assert	LOS _A	-28			dBm	
LOS Hysteresis	LOS _H	1		4	dB	
Data Output Swing Differential	V _{out}	400	800	800	mV	3
LOS	High	2.0		V _{cc}	V	
	Low			0.8	V	

Note:

1. The optical power is launched into SMF.
2. PECL input, internally AC-coupled and terminated.
3. Rise and fall times, 20% to 80%, are measured following a fourth-order Bessel-Thompson filter with a bandwidth of 0.75 x clock frequency corresponding to the serial data rate.
4. UI means one period.
5. Measured with Pathological Patterns 11.88Gpbs(4096*2160 P60,100% Bars);5.94Gpbs (4096*2160 P29.97,100% Bars);2.97Gpbs (2048*1080 P50,100% Bars).
6. Internally AC-coupled, minimum input overload power for SMPTE ST 2081-1, SMPTE ST 2082-1.

Timing and Electrical

Parameter	Symbol	Min	Typical	Max	Unit
Tx Disable Negate Time	t _{on}			1	ms
Tx Disable Assert Time	t _{off}			10	µs
Time To Initialize, including Reset of Tx Fault	t _{init}			300	ms
Tx Fault Assert Time	t _{fault}			100	µs
Tx Disable To Reset	t _{reset}	10			µs
LOS Assert Time	t _{loss_on}			100	µs
LOS De-assert Time	t _{loss_off}			100	µs
Serial ID Clock Rate	f _{serial_clock}		100		KHz
MOD_DEF (0:2)-High	V _H	2		V _{cc}	V
MOD_DEF (0:2)-Low	V _L			0.8	V

Diagnostics Specification

Parameter	Range	Unit	Accuracy	Calibration
Tx Disable Negate Time	0 to +70	°C	±3°C	Internal / External

Voltage	3.0 to 3.6	V	±3%	Internal / External
Bias Current	0 to 100	mA	±10%	Internal / External
TX Power	-3to +1	dBm	±3dB	Internal / External
RX Power	-24to +1	dBm	±3dB	Internal / External

I2C Bus Interface

The I2C bus interface uses the 2-wire serial CMOS E2PROM protocol. The serial interface meets the following specifications:

- 1.Support a maximum clock rate of 280Khz.
2. Input/Output levels comply with LVCMOS/LVTTL or compatible logics.

Low: 0 – 0.8 V

High: 2.0 – 3.3 V

Undefined: 0.8 – 2.0 V

Pin Description

Pin	Signal Name	Description	Plug Seq.	Notes
1	VEET	Transmitter Ground	1	
2	TX FAULT	Transmitter Fault Indication	3	Note 1
3	TXDISABLE	Transmitter Disable	3	Note 2
4	MOD_DEF(2)	SDA Serial Data Signal	3	Note 3
5	MOD_DEF(1)	SCL Serial Clock Signal	3	Note 3
6	MOD_DEF(0)	TTL Low	3	Note 3
7	Rate Select	Not Connected	3	
8	LOS	Loss of Signal	3	Note 4
9	VEER	Receiver ground	1	
10	VEER	Receiver ground	1	
11	VEER	Receiver ground	1	
12	RD-	Inv. Received Data Out	3	Note 5
13	RD+	Received Data Out	3	Note 5
14	VEER	Receiver ground	1	
15	VCCR	Receiver Power Supply	2	
16	VCCT	Transmitter Power Supply	2	
17	VEET	Transmitter Ground	1	
18	TD+	Transmit Data In	3	Note 6
19	TD-	Inv. Transmit Data In	3	Note 6

20	VEET	Transmitter Ground	1	
----	------	--------------------	---	--

Note:

Plug Seq.: Pin engagement sequence during hot plugging.

1. TX Fault is an open collector output, which should be pulled up with a 4.7k~10kΩ resistor on the host board to a voltage between 2.0V and Vcc+0.3V. Logic 0 indicates normal operation; Logic 1 indicates a laser fault of some kind. In the low state, the output will be pulled to less than 0.8V.

2. TX Disable is an input that is used to shut down the transmitter optical output. It is pulled up within the module with a 4.7k~10kΩ resistor. Its states are:

Low (0 ~0.8V):	Transmitter on
(0.8V ~ 2.0V):	Undefined
High (2.0 ~3.465V):	Transmitter Disabled
Open:	Transmitter Disabled

3. Mod-Def 0,1,2. These are the module definition pins. They should be pulled up with a 4.7k~10kΩ resistor on the host board to VCCT or VCCR.

Mod-Def 0 is grounded by the module to indicate that the module is present.

Mod-Def 1 is the clock line of two wire serial interface for serial ID.

Mod-Def 2 is the data line of two wire serial interface for serial ID.

4. LOS is an open collector output, which should be pulled up with a 4.7k~10kΩ resistor on the host board to a voltage between 3.15V and 3.6V. Logic 1 indicates loss of signal; Logic 0 indicates normal operation. In the low state, the output will be pulled to less than 0.8V.

5. RD-/+: These are the differential receiver outputs. They are internally AC-coupled 100 differential lines which should be terminated with 100Ω (differential) on the host .

6. TD-/+: These are the differential transmitter inputs. They are internally AC-coupled, differential lines with 100Ω differential termination inside the module.

Pin Definition

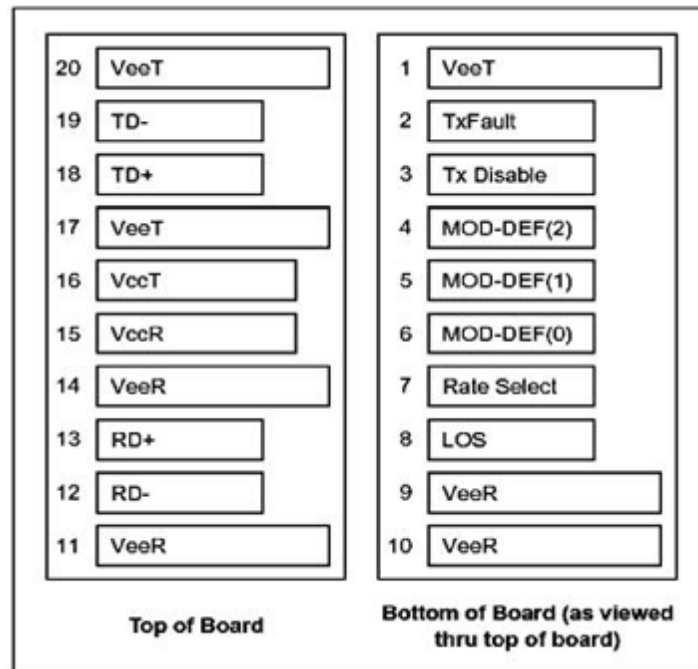

Figure 2. Electrical Pin-out Details

Mechanical Dimensions

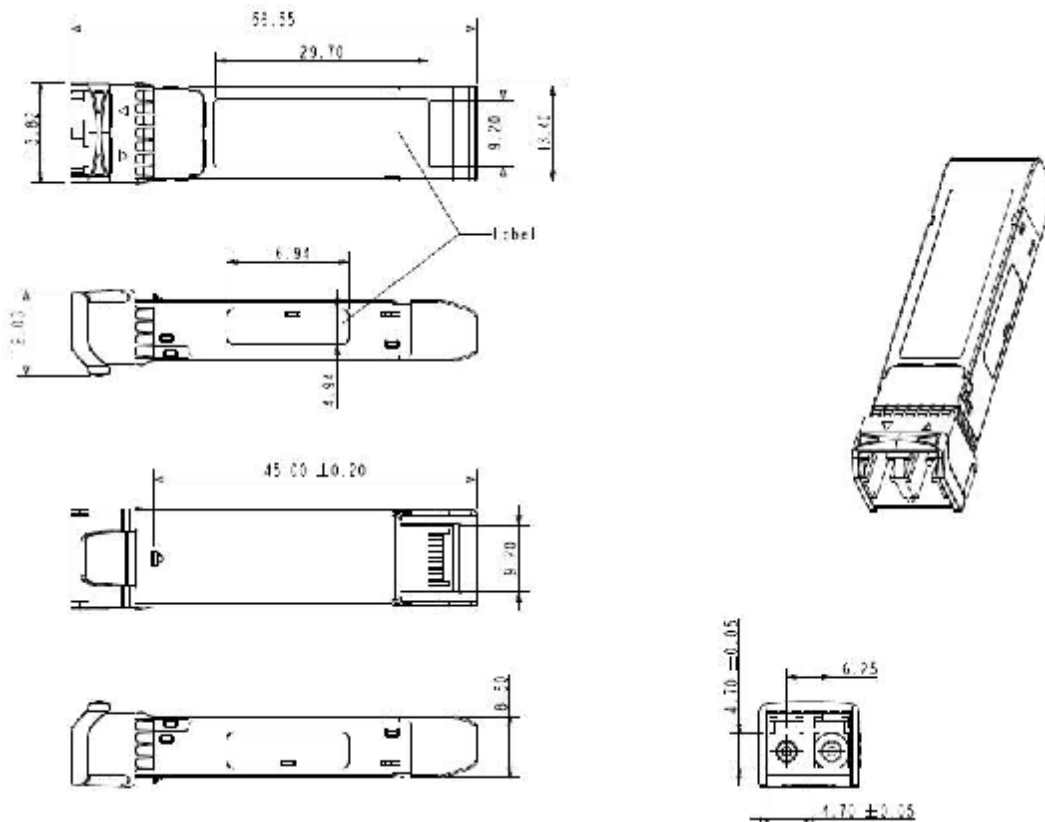

Figure 3. Mechanical Specifications

Regulatory Compliance

Feature	Standard
Laser Safety	IEC 60825-1:2014 (Third Edition)
Environmental protection	2011/65/EU
CE EMC	EN55032: 2015 EN55035: 2017 EN61000-3-2:2014 EN61000-3-3:2013
FCC	FCC Part 15, Subpart B; ANSI C63.4-2014
Product Safety	EN/UL 60950-1, 2nd Edition, 2014-10-14

CAUTION:

Use of controls or adjustment or performance of procedures other than those specified herein may result in hazardous radiation exposure.

Ordering Information

Part Number	Product Description
3CV-SFP+12G-LR	1310nm, 12Gbps, 10/20km,SD/HD/3G/6G/12G SDI Transceiver, MSA



Specifications are subject to change without notice. It is a registered trademark of 3C-LINK Technology Co., Ltd. Other brands and product names are trademarks or registered trademarks of their respective holders. No part of the specifications can reproduced in any form or by any means or used to make any derivative such as translation, transformation, or adaptation without permission from 3C-LINK Technology Co., Ltd.