

3CW-SFP+-23/32-LH

10Gbps SFP+ Bi-Directional Transceiver, 20km Reach
1270/1330nm TX / 1330/1270 nm RX

Features

- ◆ Supports 9.95Gb/s to 10.3Gb/s data rates
- ◆ Simplex LC Connector Bi-Directional SFP+ Optical Transceiver
- ◆ Single 3.3V Supply
- ◆ Up to 20km on 9/125um SMF
- ◆ A:1270nm DFB Laser transmitter,1330nm receiver
B:1330nm DFB Laser transmitter,1270nm receiver
- ◆ Compliant with IEEE 802.3ae 10GBASE-LR
and 10GBASE-LW
- ◆ SFP+ MSA SFF-8431 Compliant
- ◆ Digital Diagnostic SFF-8472 Compliant
- ◆ RoHS compliant and Lead Free
- ◆ Operating case temperature:
Standard: 0 ~ 70 °C

Applications

- ◆ 10GBASE-LR at 10.3125Gbps
- ◆ 10GBASE-LW at 9.953Gbps
- ◆ Other Optical Links

Product description

The 3CW-SFP+-23/32-LH series single mode transceiver is small form factor pluggable module for duplex optical data communications such as 10GBASE-LR/LW defined by IEEE 802.3ae. It is with the SFP+ 20-pin connector to allow hot plug capability.

The 3CW-SFP+-23/32-LH module is designed for single mode fiber and operates at a nominal wavelength of 1270nm or 1330nm; The transmitter section uses a multiple quantum well DFB, which is

class 1 laser compliant according to International Safety Standard IEC-60825.

The receiver section uses an integrated InGaAs detector preamplifier (IDP) mounted in an optical header and a limiting post-amplifier IC.

Absolute Maximum Ratings

These values represent the damage threshold of the module. Stress in excess of any of the individual Absolute Maximum Ratings can cause immediate catastrophic damage to the module even if all other parameters are within Recommended Operating Conditions.

Parameters	Symbol	Min.	Max.	Unit
Supply Voltage	V _{CC}	-0.5	+3.6	V
Storage Temperature	T _c	-40	+85	°C
Operating Case Temperature	T _c	0	+70	°C
Relative Humidity	RH	0	85	%

Recommended Operating Conditions

Parameter	Symbol	Min.	Typical	Max	Unit
Supply Voltage	V _{CC}	3.0	3.3	3.6	V
Supply Current	I _{CC}		200	300	mA
Operating Case Temperature	T _C	0	25	70	°C
Module Power Dissipation	P _m	-	0.7	1.1	W

Notes:

[1] Supply current is shared between VCCTX and VCCR_X.

[2] In-rush is defined as current level above steady state current requirements.

Electrical characteristics($T_{OP} = 0$ to 70°C , $V_{CC} = 3.0$ to 3.60 Volts)

Parameter	Symbol	Min.	Typical	Max	Unit	Ref.
Supply Voltage	V_{CC}	3.00		3.60	V	1
Supply Current	I_{CC}		200	300	mA	1
Transmitter						
Input differential impedance	R_{in}		100		Ω	2
Single ended data input swing	$V_{in,pp}$	150		1200	mVpp	
Transmit Disable Voltage	V_D	2		V_{CC}	V	
Transmit Enable Voltage	V_{EN}	Vee		Vee+0.8	V	3
Receiver						
Output differential impedance	R_{out}		100		Ω	2
Single ended data output swing	$V_{out,pp}$	300		700	mV	4
LOS Fault	$V_{LOS\ fault}$	2		$V_{CC_{HOST}}$	V	5
LOS Normal	$V_{LOS\ norm}$	Vee		Vee+0.8	V	5

Notes:

1. Module power consumption never exceeds 1W.
2. AC coupled.
3. Or open circuit.
4. Into 100 ohm differential termination.
5. LOS is LVTTTL. Logic 0 indicates normal operation; logic 1 indicates no signal detected.

Optical characteristics($T_{OP} = 0$ to 70°C , $V_{CC} = 3.0$ to 3.60 Volts)

(3CW-SFP+-23 -LH, 1270 DFB & PIN/TIA)

Parameter	Symbol	Min.	Typical	Max	Unit	Ref.
Transmitter						
Optical Wavelength	λ_c	1260	1270	1280	nm	
Side Mode Suppress Ratio	SMSR	30			dB	
Spectral Width(-20dB)	$\Delta\lambda$			1	nm	
Average Output Power	P_{op}	-2		2	dBm	1
Extinction Ratio	ER	3.5			dB	
Eye Mask		Compliant with IEEE 802.3				

Transmitter and Dispersion Penalty	TDP			3.2	dB	
Average Power of OFF Transmitter				-30	dBm	
Relative Intensity Noise	RIN			-128	dB/Hz	
Receiver						
Average Receiver Power	RSENS			-14.1	dBm	1,2
Receiver Overload	P _{MAX}			+0.5	dBm	
Centre Wavelength	λ_C	1320		1340	nm	
LOS De-Assert	LOS _D			-15	dBm	
LOS Assert	LOS _A	-30			dBm	
LOS Hysteresis		0.5			dB	

Notes:

1. Average Receiver Power (Min) is informative and not the principal indicator of signal strength. A received power below this value cannot be compliant.
2. Measured with a PRBS³¹-1 test pattern @10.3125Gbps, BER $\leq 10^{-12}$

(3CW-SFP+-32 -LH, 1330 DFB & PIN/TIA)

Parameter	Symbol	Min.	Typical	Max	Unit	Ref.
Transmitter						
Optical Wavelength	λ_C	1320	1330	1340	nm	
Side Mode Suppress Ratio	SMSR	30			dB	
Spectral Width(-20dB)	$\Delta\lambda$			1	nm	
Average Output Power	P _{op}	-2		2	dBm	1,2
Extinction Ratio	ER	3.5			dB	
Eye Mask		Compliant with IEEE 802.3				
Transmitter and Dispersion Penalty	TDP			3.2	dB	
Average Power of OFF Transmitter				-30	dBm	
Relative Intensity Noise	RIN			-128	dB/Hz	
Receiver						
Average Receiver Power	RSENS			-14.1	dBm	2,3
Receiver Overload	P _{MAX}			+0.5	dBm	

Centre Wavelength	λ_C	1260	1270	nm
LOS De-Assert	LOS _D		-15	dBm
LOS Assert	LOS _A	-30		dBm
LOS Hysteresis		0.5		dB

Notes:

1. Output is coupled into a 9/125um SMF.
2. Average Receiver Power (Min) is informative and not the principal indicator of signal strength. A received power below this value cannot be compliant.
3. Measured with a PRBS231-1 test pattern @10.3125Gbps, BER \leq 10⁻¹²

Pin Descriptions

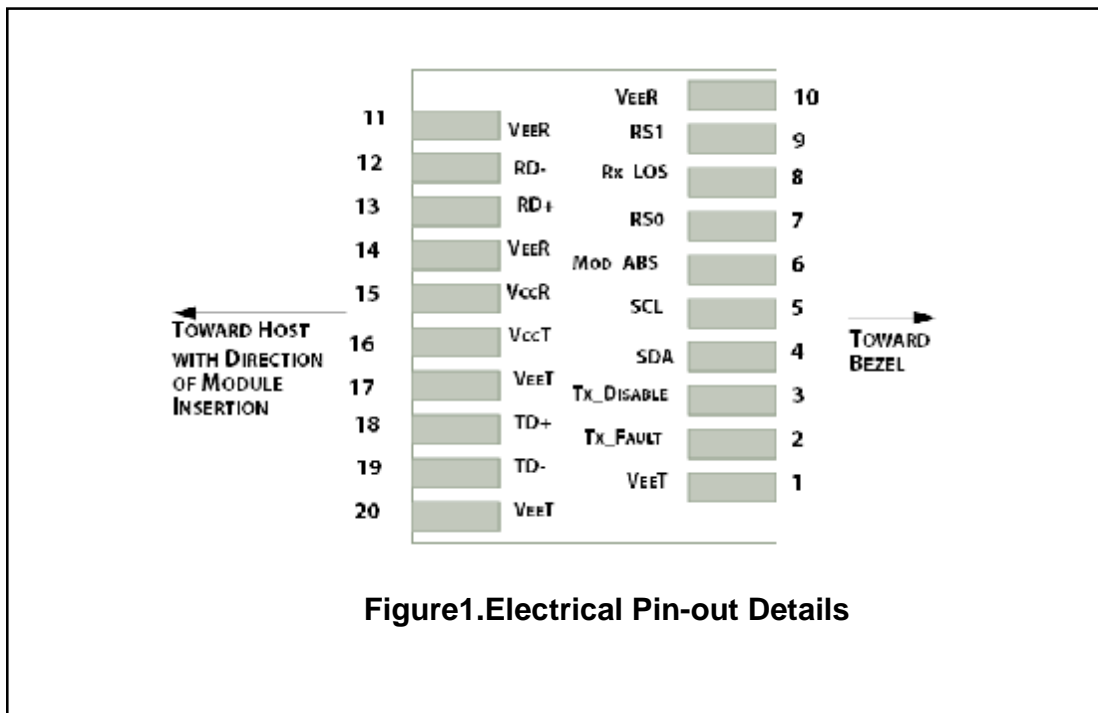

Figure1.Electrical Pin-out Details

Pin	Symbol	Name/Description
1	VEET [1]	Transmitter Ground
2	Tx_FAULT [2]	Transmitter Fault
3	Tx_DIS [3]	Transmitter Disable. Laser output disabled on high or open
4	SDA [2]	2-wire Serial Interface Data Line



5	SCL [2]	2-wire Serial Interface Clock Line
6	MOD_ABS [4]	Module Absent. Grounded within the module
7	RS0 [5]	RS0 for Rate Select: Open or Low = Module supports ≤ 4.25 Gbps High = Module supports 9.95 Gb/s to 10.3125 Gb/s
8	RX_LOS [2]	Loss of Signal indication. Logic 0 indicates normal operation
9	RS1 [5]	No connection required
10	VEER [1]	Receiver Ground
11	VEER [1]	Receiver Ground
12	RD-	Receiver Inverted DATA out. AC Coupled
13	RD+	Receiver DATA out. AC Coupled
14	VEER [1]	Receiver Ground
15	VCCR	Receiver Power Supply
16	VCCT	Transmitter Power Supply
17	VEET [1]	Transmitter Ground
18	TD+	Transmitter DATA in. AC Coupled
19	TD-	Transmitter Inverted DATA in. AC Coupled
20	VEET [1]	Transmitter Ground

Notes:

[1] Module circuit ground is isolated from module chassis ground within the module.

[2].should be pulled up with 4.7k – 10k ohms on host board to a voltage between 3.15V and 3.6V.

[3]Tx_Disable is an input contact with a 4.7 k Ω to 10 k Ω pullup to VccT inside the module.

[4]Mod_ABS is connected to VeeT or VeeR in the SFP+ module. The host may pull this contact up to Vcc_Host with a resistor in the range 4.7 k Ω to 10 k Ω .Mod_ABS is asserted “High” when the SFP+ module is physically absent from a host slot.

[5] RS0 and RS1 are module inputs and are pulled low to VeeT with > 30 k Ω resistors in the module.

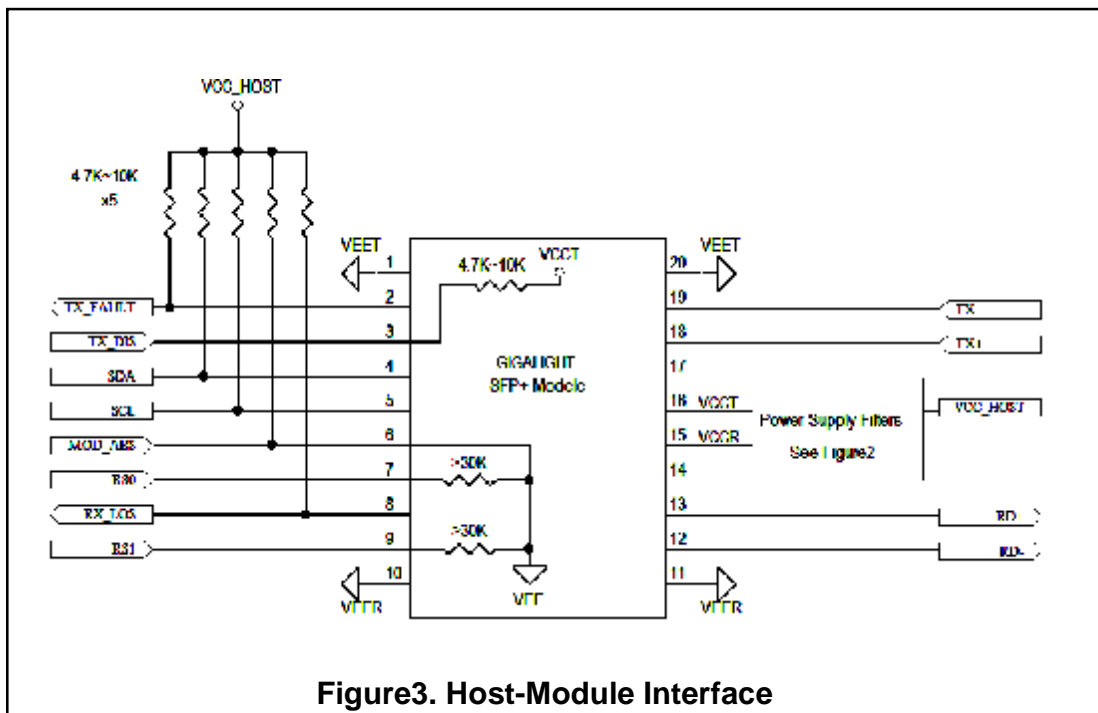
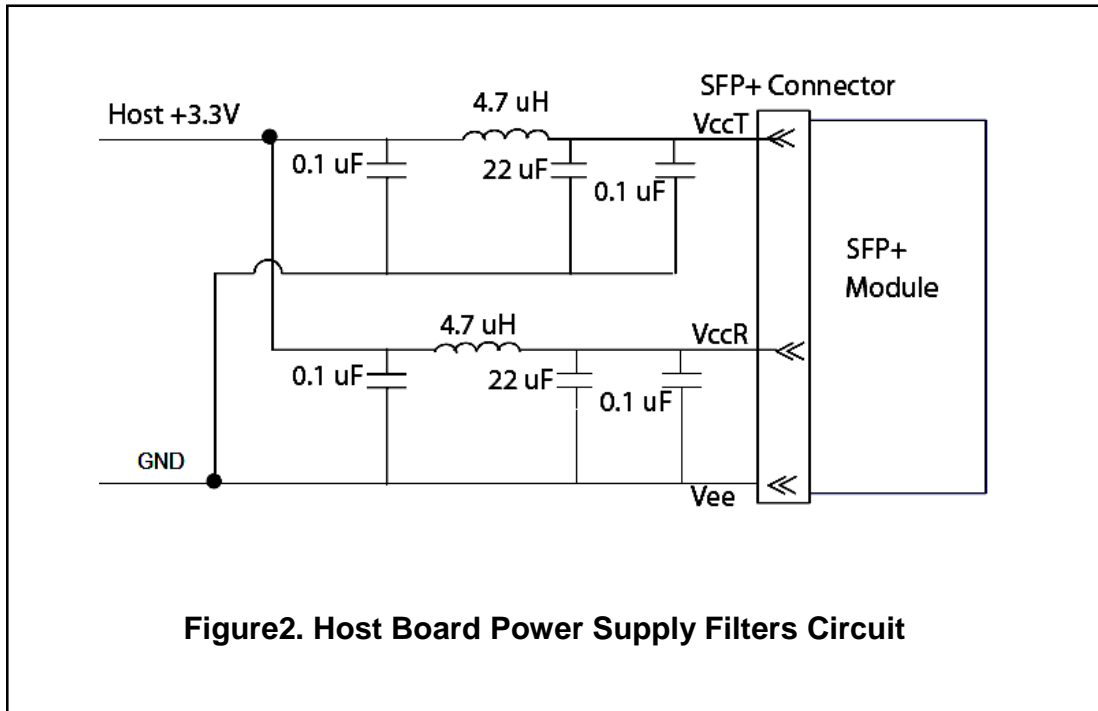

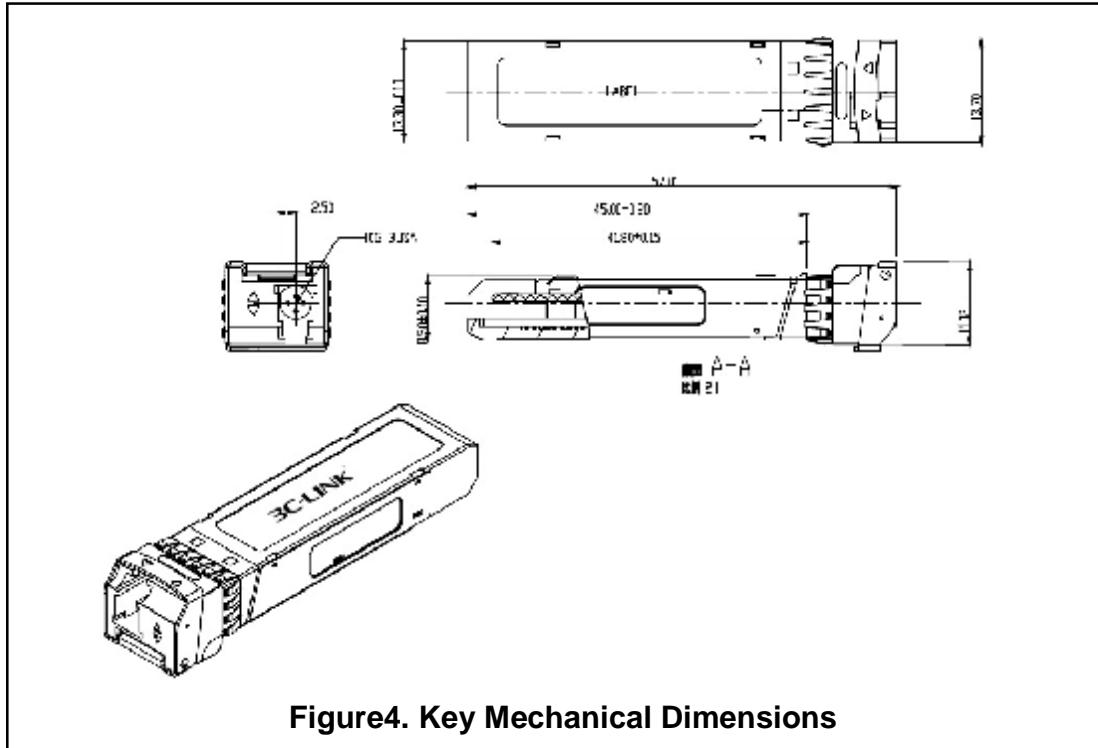

Figure4. Key Mechanical Dimensions

Ordering information

Part Number	Product Description
3CW-SFP+-23 -LH	1270nm/1330nm, 10Gbps, 20km, 0°C ~ +70°C
3CW-SFP+-32 -LH	1330nm/1270nm, 10Gbps, 20km, 0°C ~ +70°C

Important Notice

Performance figures, data and any illustrative material provided in this data sheet are typical and must be specifically confirmed in writing by 3C-LINK before they become applicable to any particular order or contract. In accordance with the 3C-LINK policy of continuous improvement specifications may change without notice.

The publication of information in this data sheet does not imply freedom from patent or other protective rights of 3C-LINK or others. Further details are available from any 3C-LINK sales representative.